



TFT MODULE SPECIFICATION

RVT70HSTNWC00-B V1.1

IPS RGB 7.0” display datasheet
Rev. 1.0
2026-05-15

Riverdi Sp. z o.o.

Nowy Swiat 36
80-299 Gdansk, Poland
VAT ID: PL5842767153
Registration number (KRS): 0000923967

+48 587 703 116

Office hours: 9:00 to 17:30 CET (Mon-Fri)

contact@riverdi.com

riverdi.com



| ITEM | CONTENTS | UNIT |
|--------------------------------|-------------------------------------|-------------------|
| LCD Type | TFT/Transmissive/Normally black/IPS | / |
| Size | 7.0 | Inch |
| Viewing Direction | Free | / |
| Outside Dimensions (W x H x D) | 179.96 x 119.00 x 7.38 | mm |
| Active Area (W x H) | 154.21 x 85.92 | mm |
| Pixel Pitch (W x H) | 0.1506 x 0.1432 | mm |
| Resolution | 1024 (RGB) x 600 | / |
| Brightness | 850 | cd/m ² |
| LCD Interface Type | RGB | / |
| Color Depth | 16.7 M | / |
| Pixel Arrangement | RGB Vertical Stripe | / |
| LCD Driver | EK79001HK+EK73215BCGA | / |
| With/Without Touch | With Capacitive Touch Panel | / |
| CTP IC | ILI2132A | / |
| LCD Input Voltage | 3.3 | V |
| Bonding Technology | Optical Bonding | / |
| Weight | TBD | g |

1. REVISION RECORD

| REV NO. | REV DATE | CONTENTS | REMARKS |
|---------|------------|-----------------|---------|
| 1.0 | 2026-05-15 | Initial release | |

Note 1. RoHS3 compliant

Note 2. LCM weight tolerance: $\pm 5\%$.

2. CONTENTS

| | | |
|--------|--|----|
| 1. | REVISION RECORD | 3 |
| 2. | CONTENTS | 4 |
| 3. | MODULE CLASSIFICATION INFORMATION | 5 |
| 4. | ASSEMBLY | 6 |
| 4.1 | uxTouch Assembly | 6 |
| 5. | MODULE DRAWING | 7 |
| 6. | ABSOLUTE MAXIMUM RATINGS | 8 |
| 7. | ELECTRICAL CHARACTERISTICS | 8 |
| 8. | Touch panel CHARACTERISTICS | 9 |
| 9. | BACKLIGHT ELECTRICAL CHARACTERISTICS | 9 |
| 10. | ELECTRO-OPTICAL CHARACTERISTICS | 10 |
| 11. | INTERFACES DESCRIPTION | 13 |
| 11.1 | TFT ASSIGNMENT | 13 |
| 11.2 | Touch Panel Connector | 14 |
| 11.3 | CN1 assignment | 14 |
| 12. | TIMING CHART | 15 |
| 12.1 | Vertical Input Timing | 15 |
| 12.2 | Horizontal Input Timing | 15 |
| 12.3 | Parallel RGB Timing Characteristic | 16 |
| 12.3.1 | DE Mode | 16 |
| 12.3.2 | HV Mode (Horizontal input timing) | 16 |
| 12.3.3 | HV Mode (Vertical input timing) | 17 |
| 13. | INSPECTION | 17 |
| 14. | RELIABILITY TEST | 18 |
| 15. | LEGAL INFORMATION | 19 |
| 16. | CONTACT | 20 |

3. MODULE CLASSIFICATION INFORMATION

| | | | | | | | | | | | |
|----|----|----|----|----|----|----|----|----|-----|-----|-------|
| RV | T | 70 | H | S | T | N | W | C | 00 | B | V1.1A |
| 1. | 2. | 3. | 4. | 5. | 6. | 7. | 8. | 9. | 10. | 11. | 12. |

| NO. | PARAMETER | SYMBOL |
|-----|--------------------|----------------------------------|
| 1. | BRAND | RV - Riverdi |
| 2. | PRODUCT TYPE | T - TFT Standard |
| 3. | DISPLAY SIZE | 70 - 7.0" |
| 4. | MODEL SERIAL NO. | H - High Brightness, IPS |
| 5. | RESOLUTION | S - 1024 x 600 px |
| 6. | INTERFACE | T - TFT LCD, RGB |
| 7. | FRAME | N - Without Mounting Metal Frame |
| 8. | BACKLIGHT TYPE | W - LED White |
| 9. | TOUCH PANEL | C - With Capacitive Touch Panel |
| 10. | VERSION | 00 - uxTouch |
| 11. | BONDING TECHNOLOGY | B - Optical Bonding |
| 12. | MODULE REVISION | V1.1A |

4. ASSEMBLY

4.1 uxTouch Assembly

uxTouch are LCD TFT displays with specially designed projected capacitive touch panels. uxTouch display can be mounted without any additional holes in the housing. Our standard uxTouch displays include double-sided adhesive tape (DST) to stick TFT easily to the housing.

uxTouch models with double-side adhesive tape can be mounted by fastening the glass to the housing.

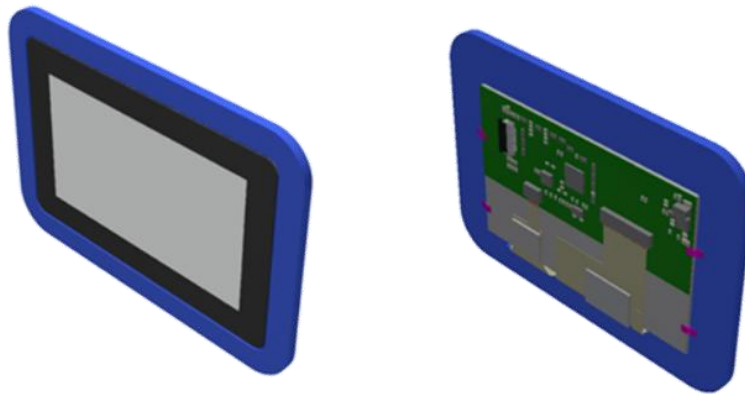
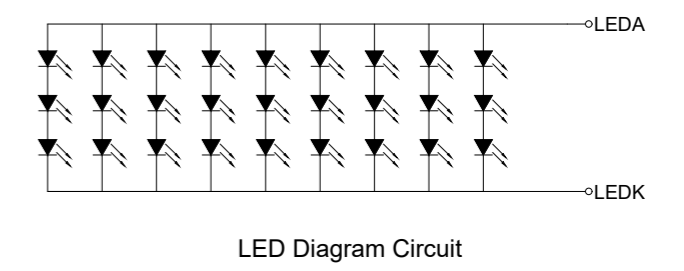
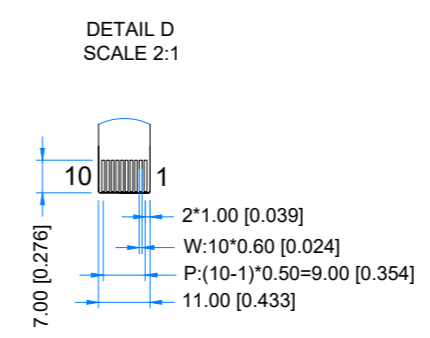
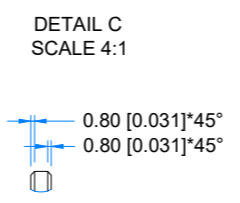
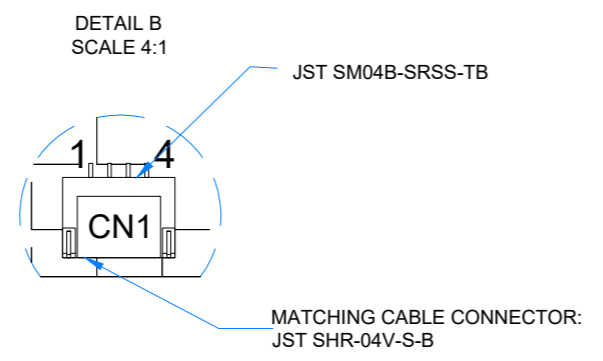
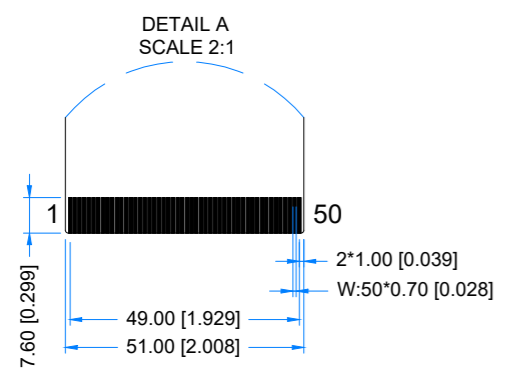
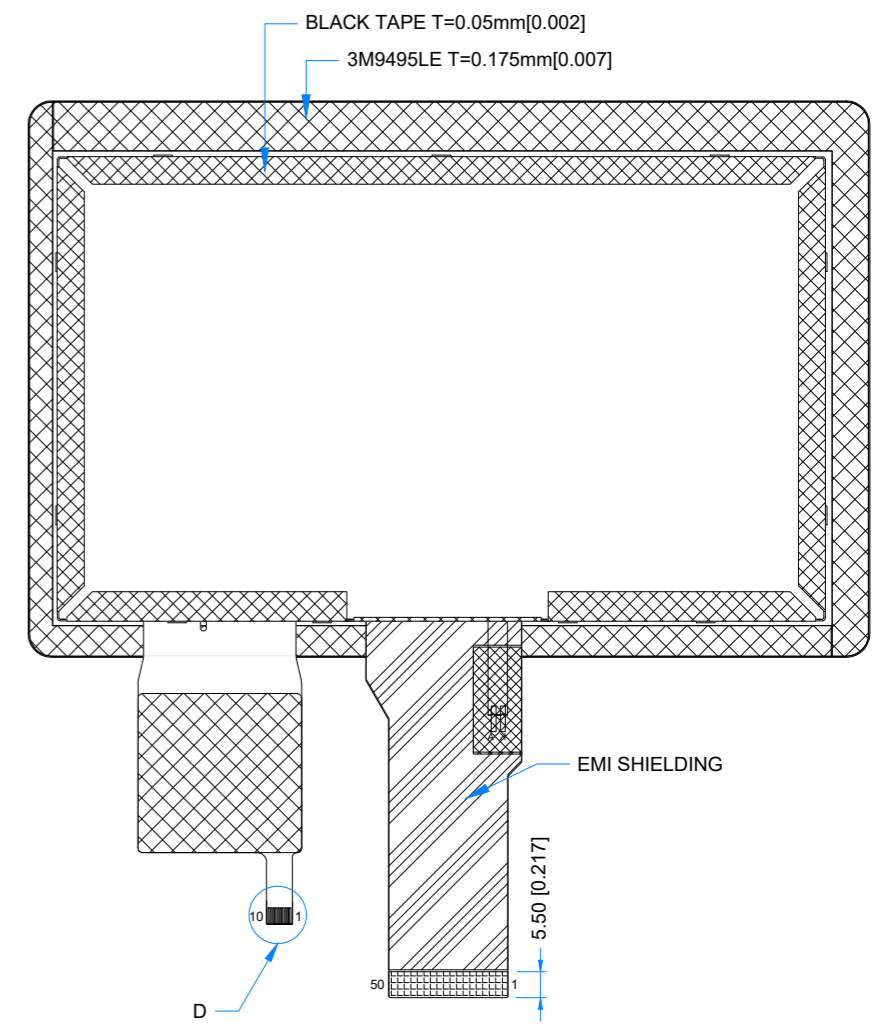
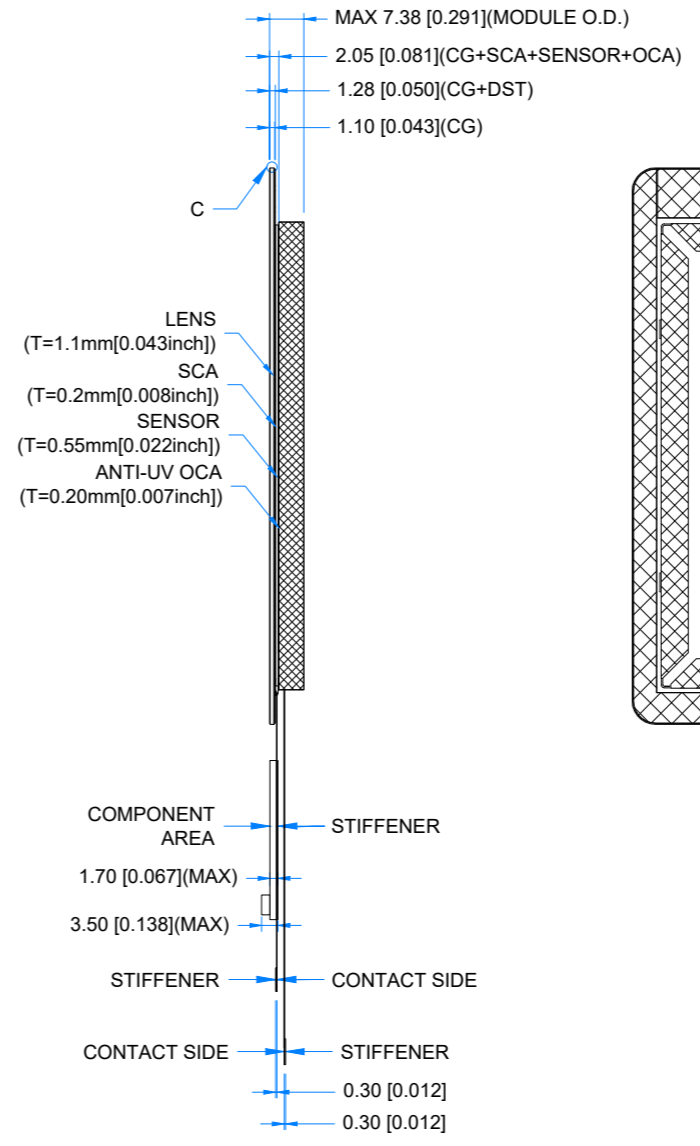
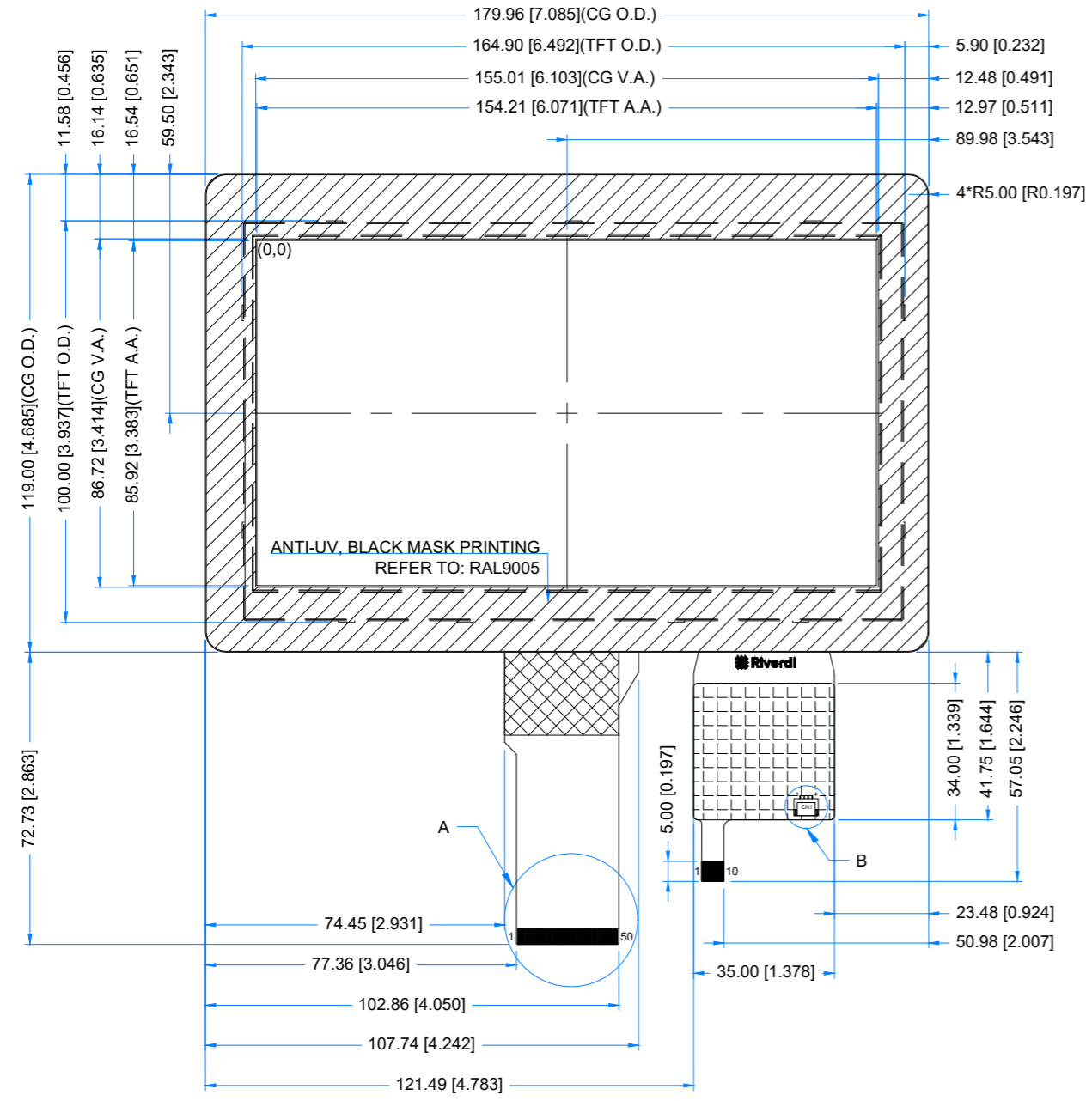

Figure 1. General view of the module



TFT NOTES:

- LCD TYPE: TRANSMISSIVE, NORMALLY BLACK, IPS
- RESOLUTION: 1024x600
- VIEWING ANGLE: FREE
- IC CONTROLLER: EK79001HK+EK73215BCGA
- OPERATING VOLTAGE: 3.3V
- INTERFACE: RGB
- BACKLIGHT: 27 LEDS WHITE, Vf = 8.4-10.2V, If = 270mA

TP NOTES:

- TP STRUCTURE: G+G
- CG THICKNESS: 1.10 mm
- DRIVER IC: ILI2132A
- INTERFACE: USB /I2C
- OPERATING VOLTAGE: 3.3V(CTP I2C); 5.0V(CTP USB)

GENERAL NOTES:

- MODULE SURFACE LUMINANCE: 850 cd/m²
- OPERATING TEMPERATURE: -20°C ~ 70°C
- STORAGE TEMPERATURE: -30°C ~ 80°C
- WITHOUT INDIVIDUAL TOLERANCE: ±0.3mm
- RoHS3 COMPLIANT

| | | | |
|---------------------------|------------|--------|--|
| PN: RVT70HSTNWC00-B V1.1A | | | |
| SN: | | | |
| DRAWN: M.Stabinski | 2026.03.19 | 1:1.62 | |
| CHECKED: M.Wierzbowski | 2026.03.19 | [mm] | |
| APPR: M.Wierzbowski | 2026.03.19 | ISO A3 | |

6. ABSOLUTE MAXIMUM RATINGS

| PARAMETER | SYMBOL | MIN | MAX | UNIT | REMARK |
|---------------------------|----------|------|------|------|---------------------|
| Analog supply voltage | V_{CI} | -0.3 | +3.6 | V | - |
| Backlight Forward Current | I_F | - | 40 | mA | For each serial LED |
| Operating Temperature | T_{OP} | -20 | 70 | °C | - |
| Storage Temperature | T_{ST} | -30 | 80 | °C | - |

Note. The above are maximum values. If exceeded, they may cause permanent damage to the unit.

7. ELECTRICAL CHARACTERISTICS

| PARAMETER | | SYMBOL | MIN | TYP | MAX | UNIT | REMARK |
|------------------------|------------|-----------|-------------|------|-------------|------|---|
| Digital supply voltage | | V_{DD} | 3.0 | 3.3 | 3.6 | V | - |
| | | A_{VDD} | 8.9 | 9.0 | 9.1 | V | |
| | | V_{GH} | 17 | 18 | 19 | V | |
| | | V_{GL} | -6.5 | -6.0 | -5.5 | V | |
| | | V_{COM} | 3.0 | 3.15 | 3.3 | V | |
| Input Signal Voltage | Low Level | V_{IL} | 0 | - | $0.3V_{DD}$ | V | RXIN0- ,RXIN0+,RXI N1- ,RXIN1+,RXI N2- ,RXIN2+SELB ,RESET,STBY B,L/R,U/D |
| | High Level | V_{IH} | $0.7V_{DD}$ | - | V_{DD} | V | |

| | | | | | | |
|----------------------------|-----------|---|-----|---|----|--|
| Touch Panel Supply Current | I_{CTP} | - | 117 | - | mA | Measured average current, touch panel active |
|----------------------------|-----------|---|-----|---|----|--|

8. TOUCH PANEL CHARACTERISTICS

| PARAMETER | SYMBOL | VALUE | REMARK |
|--------------------------------------|-----------------------|------------------|--|
| Touch panel interface | - | I ² C | |
| I ² C 7-bit slave address | ADDR _{7-bit} | 0x41 | Standard I ² C address format |
| I ² C write address | ADDR _w | 0x82 | 8-bit address format |
| I ² C read address | ADDR _r | 0x83 | 8-bit address format |

9. BACKLIGHT ELECTRICAL CHARACTERISTICS

| PARAMETER | SYMBOL | MIN | TYP | MAX | UNIT | NOTE |
|-----------------------------|----------|-----|--------|------|-------|------------|
| Backlight Driving Voltage | V_F | 8.4 | 9.0 | 10.2 | V | Notes 1, 2 |
| Backlight Driving Current | I_F | - | 270 | - | mA | |
| Backlight Power Consumption | W_{BL} | - | 2430 | - | mW | |
| Backlight Lifetime | - | - | 30,000 | - | hours | Note 3 |

Note 1: The LED driving condition is defined for total backlight consumption, and which depend on Forward Current setting.

Note 2: Forward Voltage is just for reference for one serial.

Note 3: The “Operating lifetime” is defined as the module brightness decrease to 50% original brightness at $T_a=25^{\circ}\text{C}$ and $I_F=270\text{mA}$. The LED lifetime could be decreased if operating I_F is larger than 270mA.

10. ELECTRO-OPTICAL CHARACTERISTICS

| ITEM | SYMBOL | CONDITION | MIN | TYP | MAX | UNIT | RMK | NOTE |
|-------------------------|----------|--|-------|-------|-------|------------------------|--------|------|
| Response Time | Tr+Tf | $\theta=0^{\circ}$ $\phi=0^{\circ}$ $T_a=25^{\circ}\text{C}$ | - | 27 | 45 | ms | FIG 2. | 4, 7 |
| Contrast Ratio | Cr | | 600 | 800 | - | --- | FIG 3. | 1, 7 |
| Surface Luminance | Lv | | - | 850 | - | cd/m^2 | | 2, 7 |
| Uniformity | U | - | 70 | 75 | - | % | FIG 3. | 3 |
| Viewing Angle Range | θ | $\phi = 90^{\circ}$ | 80 | 85 | - | deg | FIG 4. | 6 |
| | | $\phi = 270^{\circ}$ | 80 | 85 | - | deg | | |
| | | $\phi = 0^{\circ}$ | 80 | 85 | - | deg | | |
| | | $\phi = 180^{\circ}$ | 80 | 85 | - | deg | | |
| CIE (x, y) Chromaticity | Rx | $\theta=0^{\circ}$ $\phi=0^{\circ}$ $T_a=25^{\circ}\text{C}$ | 0.581 | 0.611 | 0.641 | - | FIG 3. | 5,7 |
| | Ry | | 0.295 | 0.325 | 0.355 | - | | |
| | Gx | | 0.306 | 0.336 | 0.366 | - | | |
| | Gy | | 0.513 | 0.543 | 0.573 | - | | |
| | Bx | | 0.117 | 0.148 | 0.178 | - | | |
| | By | | 0.127 | 0.157 | 0.187 | - | | |
| | Wx | | 0.291 | 0.321 | 0.351 | - | | |

| | | | | | | | | |
|------------|----|--|-------|-------|-------|---|--|--|
| | Wy | | 0.315 | 0.345 | 0.375 | - | | |
| NTSC ratio | - | | 40 | 47 | - | % | | |

Note 1. Contrast Ratio (CR) is defined mathematically as below, for more information see Figure 2.

$$\text{Contrast Ratio} = \frac{\text{Average Surface Luminance with all white pixels (P1, P2, P3, P4, P5)}}{\text{Average Surface Luminance with all black pixels (P1, P2, P3, P4, P5)}}$$

Note 2. Surface luminance is the LCD surface from the surface with all pixels displaying white. For more information see Figure 2.

$$L_v = \text{Average Surface Luminance with all white pixels (P1, P2, P3, P4, P5)}$$

Note 3. The uniformity in surface luminance δ WHITE is determined by measuring luminance at each test position 1 through 5, and then dividing the minimum luminance of 5 points luminance by maximum luminance of 5 points luminance. For more information see Figure 2.

$$\delta \text{ WHITE} = \frac{\text{Minimum Surface Luminance with all white pixels (P1, P2, P3, P4, P5)}}{\text{Maximum Surface Luminance with all white pixels (P1, P2, P3, P4, P5)}}$$

Note 4. Response time is the time required for the display to transition from white to black (Rise Time, Tr) and from black to white (Decay Time, Tf). For additional information see Figure 1. The test equipment is BM-7A.

Note 5. CIE (x, y) chromaticity, the x, y value is determined by measuring luminance at each test position 1 through 5, and then make average value.

Note 6. For TFT module, viewing angle is the angle at which the contrast ratio is greater 10. The angles are determined for the horizontal or x axis and the vertical or y axis with respect to the z axis which is normal to LCD surface. For more information see Figure 3.

Note 7. Viewing angle is measured at the center point of the LCD by CONOSCOPE (ergo-80). For response time testing, the testing data is based on BM-7A. Instruments for Contrast Ratio, Surface Luminance, Luminance Uniformity, Chromaticity the test data is based on SR-3A.

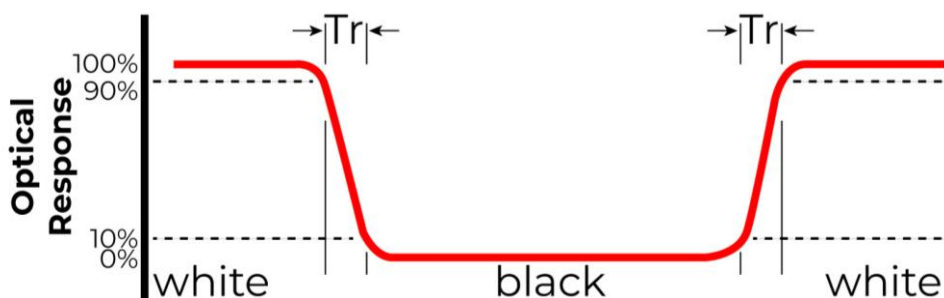

Figure 2. The definition of response time

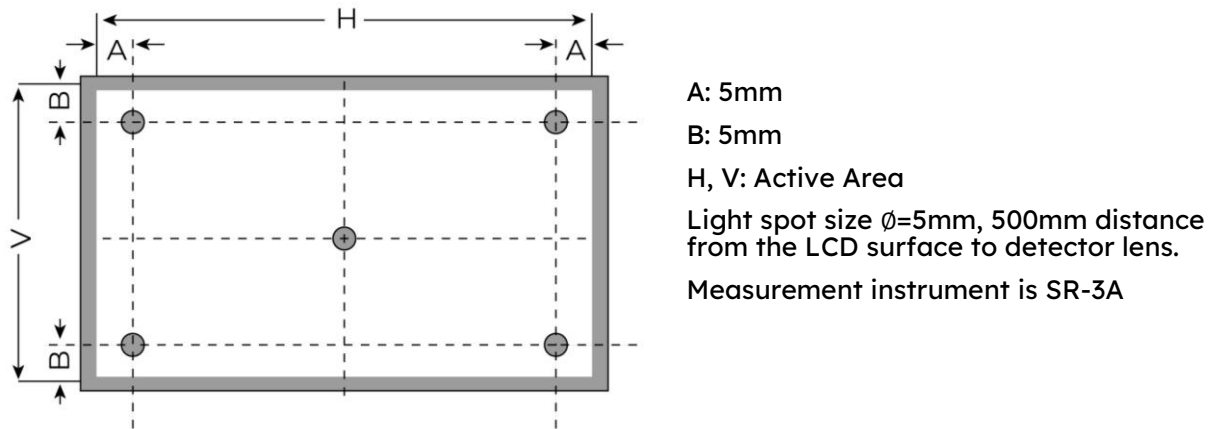

Figure 3. Measuring method for Contrast ratio, surface luminance, Luminance uniformity, CIE (x, y) chromaticity

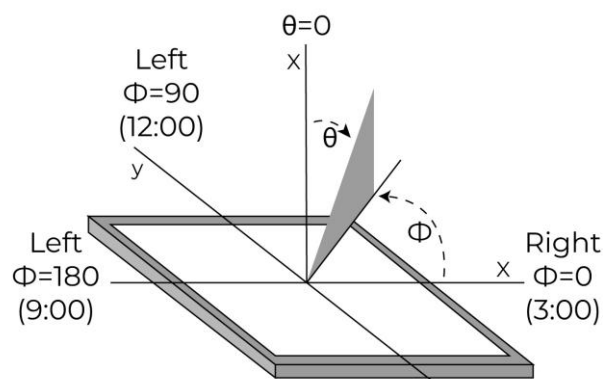

Figure 4. The definition of viewing angle

11. INTERFACES DESCRIPTION

11.1 TFT ASSIGNMENT

| PIN | SYMBOL | I/O/P | DESCRIPTION |
|--------------|--------|-------|-----------------------------------|
| 1 | VLED+ | P | Power for LED backlight (Anode) |
| 2 | VLED+ | P | Power for LED backlight (Anode) |
| 3 | VLED- | P | Power for LED backlight (Cathode) |
| 4 | VLED- | P | Power for LED backlight (Cathode) |
| 5 | GND | P | Ground |
| 6 | VCOM | P | Common voltage |
| 7 | DVDD | P | Power for Digital Circuit |
| 8 | MODE | I | DE/SYNC mode select |
| 9 | DE | I | Data Input Enable |
| 10 | VS | I | Vertical Sync Input |
| 11 | HS | I | Horizontal Sync Input |
| 12-19 | B7-B0 | I | Blue data |
| 20-27 | G7-G0 | I | Green data |
| 28-35 | R7-R0 | I | Red data |
| 36 | GND | P | Ground |
| 37 | DCLK | I | Sample Clock |
| 38 | GND | P | Ground |
| 39 | L/R | I | Left/right selection |
| 40 | U/D | I | Up/down selection |
| 41 | VGH | P | Gate ON voltage |
| 42 | VGL | P | Gate OFF voltage |

| | | | |
|--------------|-------|---|----------------------------|
| 43 | AVDD | P | Power for Analog Circuit |
| 44 | RESET | I | Global reset pin |
| 45 | STBYB | I | ON display and OFF display |
| 46 | VCOM | P | Common voltage |
| 47 | DITHB | I | Dithering function |
| 48 | GND | P | Ground |
| 49-50 | NC | - | No connection |

11.2 Touch Panel Connector

| PIN | SYMBOL | DESCRIPTION |
|-----------|---------|---|
| 1 | USB_GND | USB Ground |
| 2 | USB_VDD | USB Power for CTP, 5.0V |
| 3 | USB_D- | USB Data signal- |
| 4 | USB_D+ | USB Data signal+ |
| 5 | I2C_GND | I2C Ground |
| 6 | I2C_VDD | I2C Power for CTP 3.3V |
| 7 | I2C_RST | I2C Reset pin, active low |
| 8 | I2C_SCL | I2C Clock input |
| 9 | I2C_INT | I2C Interrupt signal from CTP, active low |
| 10 | I2C_SDA | I2C Data signal |

11.3 CN1 assignment

| PIN | SYMBOL | DESCRIPTION |
|----------|---------|----------------------------|
| 1 | USB_VDD | USB_Power for CTP, DC 5.0V |
| 2 | USB_D- | USB_Data signal - |

| | | |
|---|---------|-------------------|
| 3 | USB_D+ | USB_Data signal + |
| 4 | USB_GND | USB_Ground |

12. TIMING CHART

12.1 Vertical Input Timing

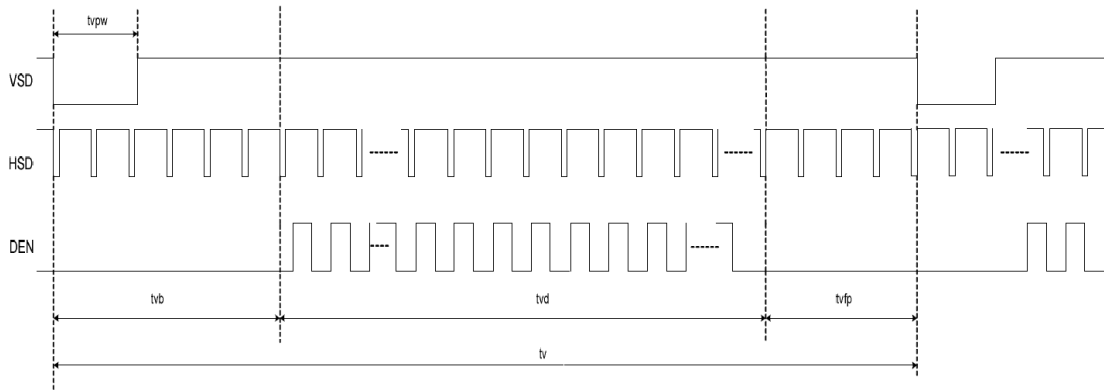

12.2 Horizontal Input Timing

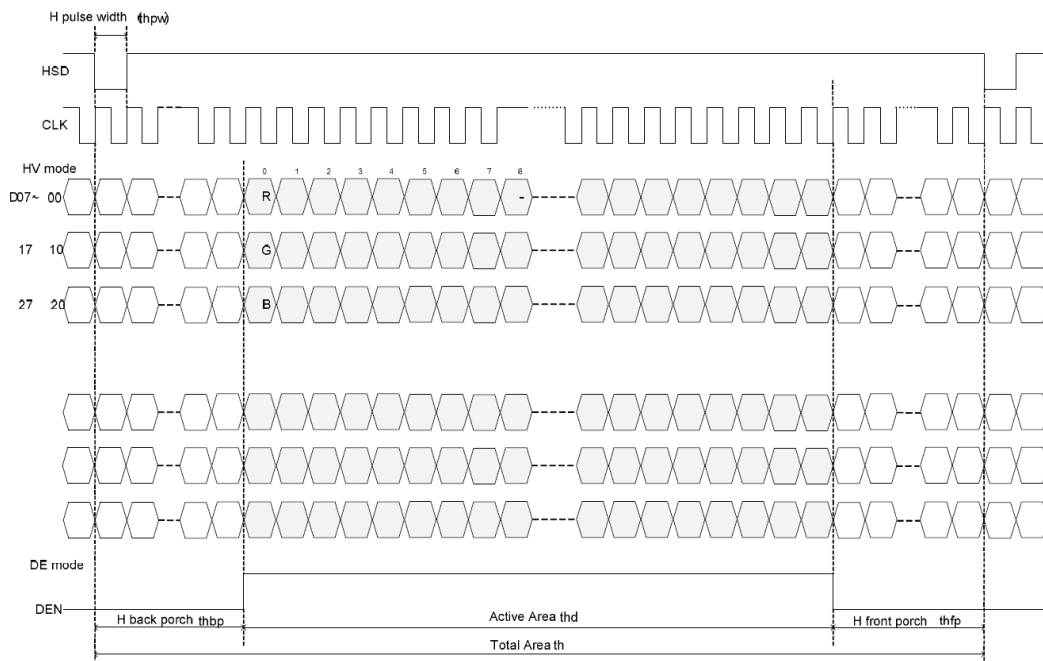

12.3 Parallel RGB Timing Characteristic

12.3.1 DE Mode

| PARAMETER | SYMBOL | MIN | TYP | MAX | UNIT |
|---------------------------------|----------|------|------|------|------|
| DCLK frequency @Frame rate=60HZ | fclk | 40.8 | 51.2 | 67.2 | MHz |
| Horizontal display area | Thd | 1024 | | | DCLK |
| HSYNC period time | Th | 1114 | 1344 | 1400 | DCLK |
| HSYNC blanking | Thb+thfp | 90 | 320 | 376 | DCLK |
| Vertical display area | Tvd | 600 | | | H |
| VSYNC period time | Tv | 610 | 635 | 800 | H |
| VSYNC blanking | Tvb+tvfp | 10 | 35 | 200 | H |

12.3.2 HV Mode (Horizontal input timing)

| PARAMETER | SYMBOL | MIN | TYP | MAX | UNIT |
|---------------------------------|--------|------|------|------|------|
| DCLK frequency @Frame rate=60Hz | Fclk | 44.9 | 51.2 | 63 | MHz |
| Horizontal display area | Thd | 1024 | | | DCLK |
| 1 Horizontal line | Th | 1200 | 1344 | 1400 | DCLK |
| HSYNC Pulse Width | Thpw | 1 | - | 140 | DCLK |
| HSYNC back porch | Thbp | 160 | 160 | 160 | DCLK |
| HSYNC front porch | Thfp | 16 | 160 | 216 | DCLK |

12.3.3 HV Mode (Vertical input timing)

| PARAMETER | SYMBOL | MIN | TYP | MAX | UNIT |
|-----------------------|--------|-----|-----|-----|------|
| Vertical display area | Tvd | 600 | | | H |
| 1 VSYNC period time | Tv | 624 | 635 | 750 | H |
| VSYNC Pulse Width | Tvpw | 1 | - | 20 | H |
| VSYNC back porch | Tvbp | 23 | 23 | 23 | H |
| VSYNC front porch | Tvfp | 1 | 12 | 127 | H |

13. INSPECTION

Standard acceptance/rejection criteria for TFT module according to document available [here](#).

14. RELIABILITY TEST

| NO. | TEST ITEM | TEST CONDITION | NOTE |
|-----|-------------------------------------|---|-----------|
| 1 | High Temperature Storage | 80°C/120 hours | A,B,C,D,E |
| 2 | Low Temperature Storage | -30°C/120 hours | |
| 3 | High Temperature Operating | 70 °C /120 hours | |
| 4 | Low Temperature Operating | -20°C/120 hours | |
| 5 | High Temperature and High Humidity | +60°C, 90%RH, 120hrs | |
| 6 | Thermal Cycling Test (No operation) | -20°C/30 min ~ +70°C/30 min for a total 10 cycles, Start with cold temperature and end with high temperature. | A,B,C,D,E |
| 7 | Vibration Test | Sweep:10Hz~55Hz~10Hz 2G 2 hours for each direction of X. Y. Z. (6 hours for total) | A,B,C,D,E |
| 8 | Package Vibration Test | Random Vibration : 0.015G*G/Hz from 5-200HZ, -6dB/Octave from 200-500HZ 2 hours for each direction of X. Y. Z. (6 hours for total) | A,B,C,D,E |
| 8 | Package Drop Test | Height: 60 cm 1 corner, 3 edges, 6 surfaces | A,B,C,D,E |
| 9 | ESD | Contact=+/-2KV, Air=+/-4KV,(R=330R,C=150pF), 1 sec,9point,10times/point; | A,B,C,D,E |

Notes

- A. LCM each function is OK.
- B. LCM appearance inspection without abnormalities (Including scratch, damage, corrosion and serious deformation)
- C. LCM brightness above the Min. value of Spec.
- D. Luminance uniformity above the Min. value of Spec.
- E. Color chromaticity within tolerance range.

15. LEGAL INFORMATION

CE marking is usually obligatory only for a complete end product. Riverdi display modules are semi-finished goods which are used as inputs to become part of the finished products.

Therefore, Riverdi display modules are not CE marked.

This is not a standalone product. It was designed as an electronic component. It needs integration with a whole system to be fully functional.

Riverdi grants the guarantee for the proper operation of the goods for a period of 12 months from the date of possession of the goods. If in a consequence of this guaranteed execution the customer has received the defects-free item as replacement for the defective item, the effectiveness period of this guarantee shall start anew from the moment the customer receives the defects-free item.

Information about device is the property of Riverdi and may be the subject of patents pending or granted. It is not allowed to copy or disclosed this document without prior written permission.

Riverdi endeavors to ensure that all contained information in this document is correct but does not accept liability for any error or omission. Riverdi products are in developing process and published information may be not up to date. Riverdi reserves the right to update and makes changes to Specifications or written material without prior notice at any time. It is important to check the current position with Riverdi.

Images and graphics used in this document are only for illustrative the purpose. All images and graphics are possible to be displayed on the range products of Riverdi, however the quality may vary. Riverdi is no liable to the buyer or to any third party for any indirect, incidental, special, consequential, punitive, or exemplary damages (including without limitation lost profits, lost savings, or loss of business opportunity) relating to any product, service provided or to be provided by Riverdi, or the use or inability to use the same, even if Riverdi has been advised of the possibility of such damages.

Riverdi products are not fault tolerant nor designed, manufactured or intended for use or resale as on line control equipment in hazardous environments requiring fail-safe performance, such as in the operation of nuclear facilities, aircraft navigation or communication systems, air traffic control, direct life support machines or weapons systems in which the failure of the product could lead directly to death, personal injury or severe physical or environmental damage ('High-Risk Activities'). Riverdi and its suppliers specifically disclaim any expressed or implied warranty of fitness for High-Risk Activities. Using Riverdi products and devices in 'High-Risk Activities' and in any other application is entirely at the buyer's risk, and the buyer agrees to defend, indemnify and hold harmless Riverdi from all damages, claims or expenses resulting from such use. No licenses are conveyed, implicitly or otherwise, under any Riverdi intellectual property rights.

16. CONTACT

Your Success is Our Priority

Stuck on a technical challenge? Need expert guidance?
Our dedicated support team is just a message away.

Contact us at

contact@riverdi.com

We're here to ensure your project's success, every step of the way!